

TABELLA DIMENSIONALE/ DIMENSIONS

MOD. QUADRUPLEX

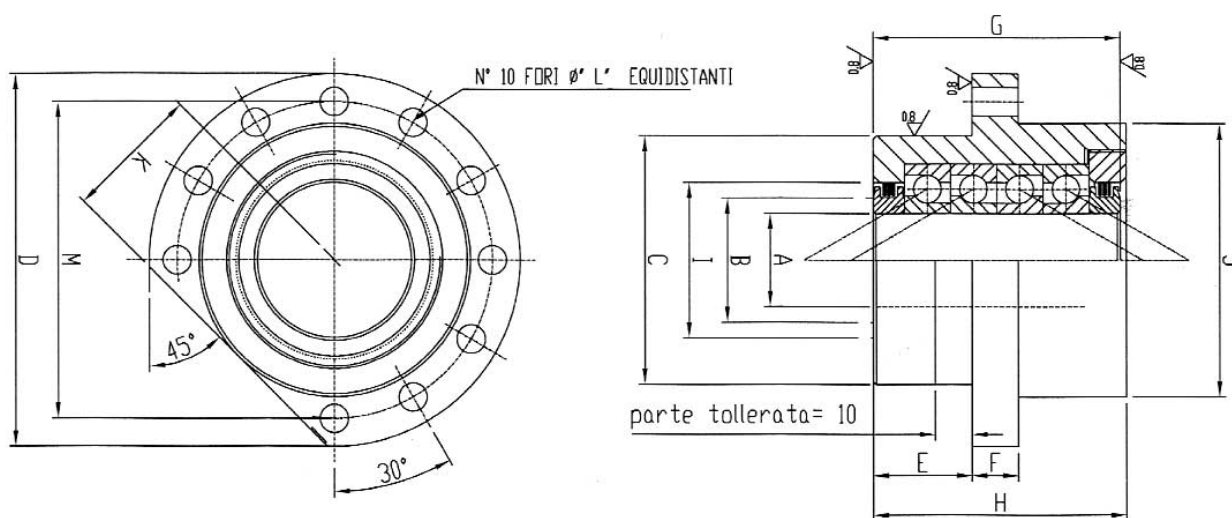

| A-Ø Shaft | Quadruplex | A | B | C | D | E | F | G | H | I | J | K | L | M | C | Co | Pr | Vg |
|-----------|------------|----|----|-----|-----|------|----|------------------|-----|----|-----|----|------|-----|------|-------|------|------|
| 20 | SUP20QC | 20 | 26 | 60 | 90 | 32 | 13 | 74.26 72.74 | 77 | 36 | 64 | 32 | 6,6 | 76 | 2950 | 6760 | 460 | 3250 |
| 25 | SUP25QC | 25 | 34 | 80 | 120 | 32 | 15 | 80.26 78.74 | 82 | 40 | 88 | 44 | 9,2 | 102 | 3240 | 8480 | 560 | 2850 |
| 30 | SUP30QC | 30 | 41 | 80 | 120 | 32 | 15 | 82.26 80.74 | 82 | 50 | 88 | 44 | 9,2 | 102 | 3985 | 10800 | 720 | 2400 |
| 35 | SUP35QC | 35 | 46 | 90 | 130 | 32 | 15 | 84.26 82.74 | 86 | 60 | 98 | 49 | 9,2 | 113 | 4950 | 14200 | 950 | 2100 |
| 40 | SUP40QC | 40 | 55 | 124 | 165 | 43.5 | 17 | 104.26 102.74 | 106 | 66 | 128 | 64 | 11.4 | 146 | 6070 | 18200 | 1200 | 1900 |

| | | |
|----|--|-----------------|
| C | Capacità di carico dinamico/ <i>Dinamic load capacity</i> | daN |
| Co | Capacità di carico assiale/ <i>Static load capacity</i> | daN |
| Pr | Prearico/ <i>Preload</i> | daN |
| Vg | Velocità massima con lubrificazione a grasso/ <i>Maximum speed with grease lubrication</i> | giri/min rpm |