

MODELLO
MOD.

CHIOCCIOLA ROTANTE
ROTATING NUT

TAB. 6
TAB. 6

- Chiocciola singola/flangiata-precaricata
- Raschiatori in PTFE
- Forma flangia in esecuzione speciale, a richiesta
- Altre configurazioni diam/passo, a richiesta
- Rotating and preloaded/flanged/single nut
- PTFE selflubricating wipers
- On request:
 1. Flange shape in special execution
 2. Other diam/pitch

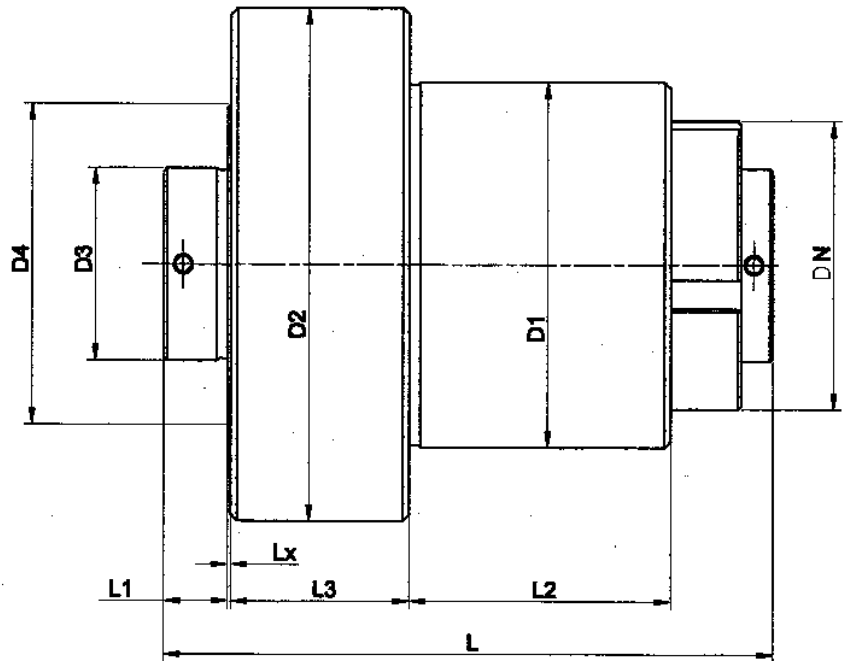

d0 mm	Ph mm	Circuiti i	Sfera (φ) Dw mm	rpm max chiocciola (*1)	C stat. C0a (KN)	C dyn. Ca (KN)	D1 g6 mm	D2±0,1 mm	D3 g6 mm
20	10	5	3,175	3000	32	20	60	80	35
25	6	5	4,5	3000	55	36	70	95	43
32	6	5	4,5	3000	69	40	75	110	49
	10	4	6,35	3000	75	51	85	120	55
40	6	6	4,5	3000	75	32	90	125	54
	10	6	6,35	3000	149	84	95	130	62
	20	4	9,52	3000	142	97	105	140	73
	40	2	9,52	3000	64	49			73
50	10	5	6,35	3000	157	79	120	155	72
	20	3	9,52	3000	131	84			83
63	10	5	6,35	3000	197	87	120	170	85
	20	5	9,52	2450	291	151	140	190	95
80	20	6	12,7	2000	628	300	190	270	125
100	20	6	12,7	1600	790	331	220	300	135
	40	6	12,7	1600	790	330			135
120	20	6	12,7	1500	951	358	250	330	170

(*1) Valori con lubrificazione ad olio. Con lubrificazione a grasso ridurre i valori del 30%.

Verificare che tali valori siano compatibili con le limitazioni applicative della vite stessa.

(*1) Values with oil lubrication. With grease lubrication the values must be reduced by 30%.

Check and make sure such values are compatible with the application limits of the ballscrew.

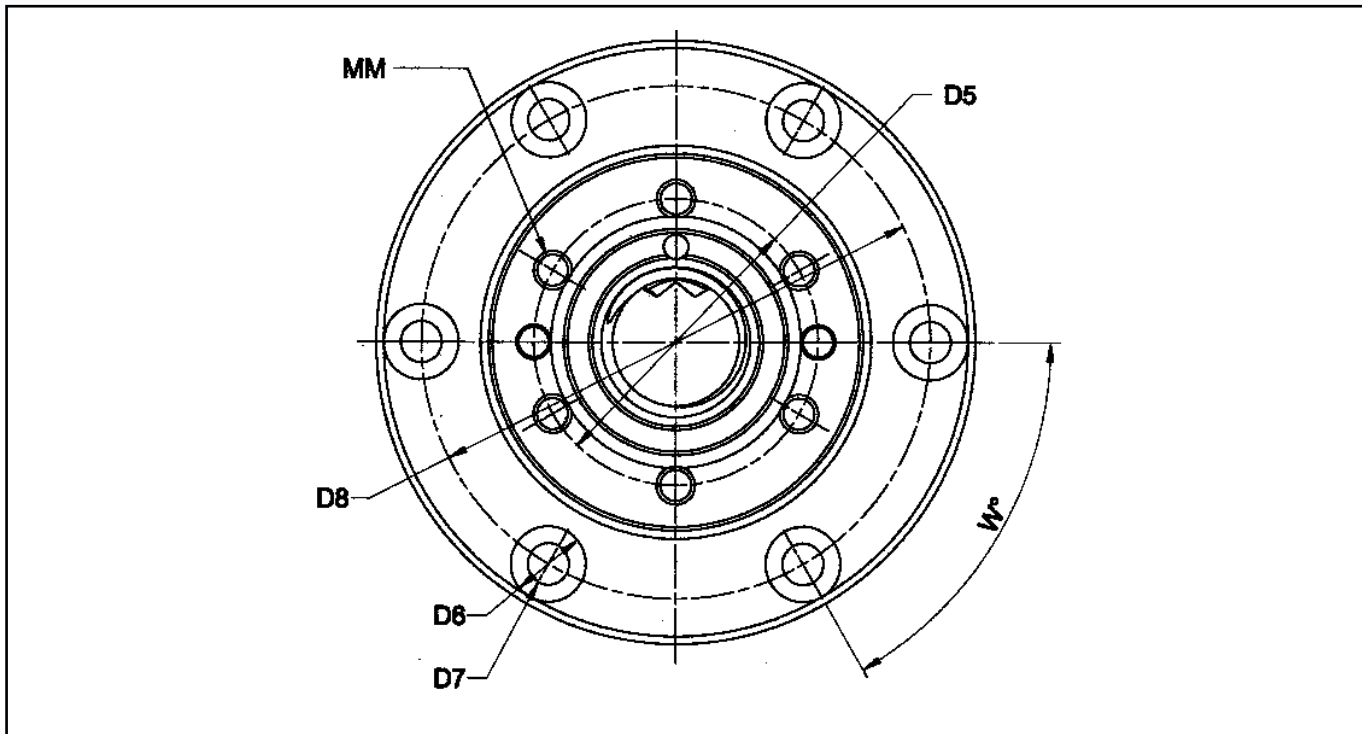

D4±0,1 mm	D5±0,1 mm	D6 mm	D7 mm	D8±0,1 mm	DN mm	L mm	L1 mm	L2 mm	L3 mm	Lx mm	MM	W (*2)	
55	43	10	5,5	68	52	119,5	10	66	28	0,5	M5	6x60°	
65	52	11	6,6	82	58	119	15	50	35		M6		
75	60	15	9	93	65	131,5	15	67,5	35		M8		8x45°
78	63			100	70	139,5		68	40				
85	68	15	9	105	75	136,5	15	61	40				
90	73			110	80	155,5		79	40				
105	86	15	9	122	85	187	15	103	45				
					85	190,5		107					
110	90	15	9	136	105	171	15	92	47				
115	95					192,5		112					
115	96	18	11	145	105	183,5	15	102	45				
135	110	20	13,5	165	110	204,5		112	55				
170	144	26	17,5	230	155	252	20	138	70		M10	12x30°	
200	166	33	22	260	195	282	30	158	70				
						400		276					
225	190	33	22	290	220	280	30	156	70	M16	12x30°		

(*2) Per il fissaggio della flangia, utilizzare viti in classe 10,9.

(*2) To fix the flange, use 10,9 class screws.